

Safety Instructions

For GreenPin-shackle acc. to EN 13889 – Manufacturer mark G.P

Translation of original safety instructions

1. Instructions for use

Shackles should be inspected before use to ensure that:

- all markings are legible;
- the body and pin are both identifiable as being of the same size, type and make;
- the threads of the pin and the body are undamaged;
- never use a safety bolt type shackle without using a securing pin;
- the body and the pin are not distorted or unduly worn;
- the body and pin are free from nicks, gouges, cracks and corrosion;
- shackles may not be heat treated as this may affect their Working Load Limit;
- never modify, repair or reshape a shackle by machining, welding, heating or bending as this will affect the Working Load Limit.

Revisionsstand 12/2016

2. Assembly

Ensure that the pin is correctly screwed into the shackle eye, i.e. tighten hand-tight, then secure using a wrench or other suitable tool so that the collar of the pin is fully seated on the shackle eye. Ensure that the pin is of the correct length so that it penetrates the full depth of the screwed eye and allows the collar of the pin to seat on the surface of the shackle eye.

Incorrect seating of the pin may be due to a bent pin, too tight fitting thread or misalignment of the pin holes. Do not use the shackle under these circumstances. Never replace a shackle pin except with one of the same size, type and make as it may not be suitable for the loads imposed.

Select the correct type of shackle and its Working Load Limit for the particular application. Should extreme circumstances or shock loading be applicable, this must be well taken into account on selecting the correct shackle. Please note that commercial shackles are not to be used for lifting applications.

Make sure that the shackle is supporting the load correctly, i.e. along the axis of the shackle body centreline, avoid introduction of bending loads, unstable loads and do not apply overloads. Support width at shackle pin must measure between 60% to 90% of inner shackle width.

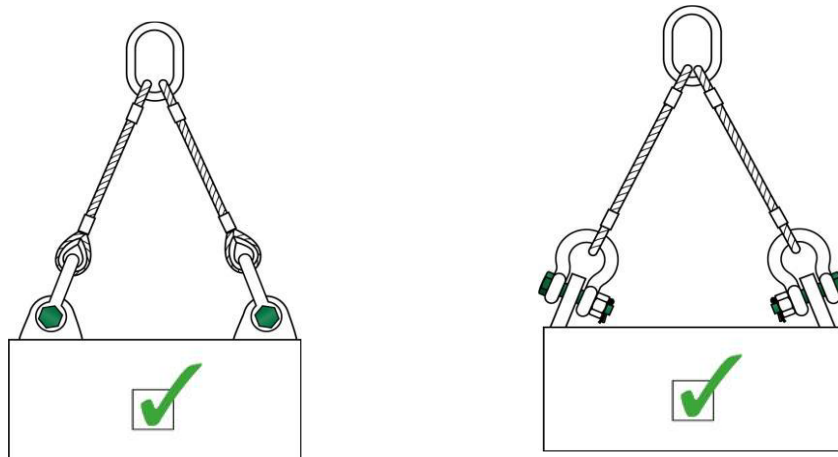

3. Side loads

Remark: Chapter „Side loads“ is not valid for GreenPin Sling shackles. If you want to use Sling shackles with side loads, please contact your sales engineer.

Side loads should be avoided as well, as the products are not designed for this purpose. If side loads cannot be avoided, the following reduction factors must be taken into account:

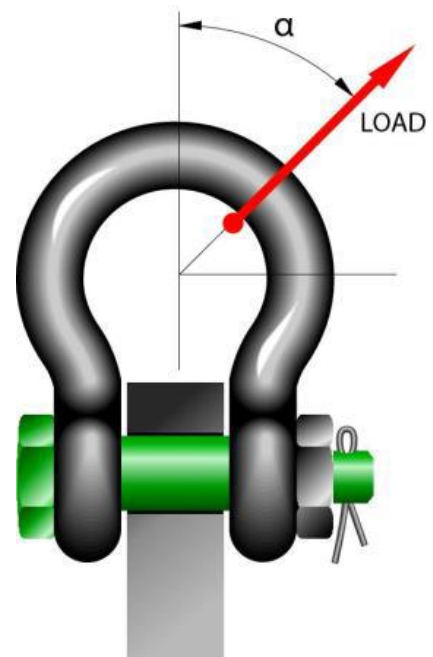
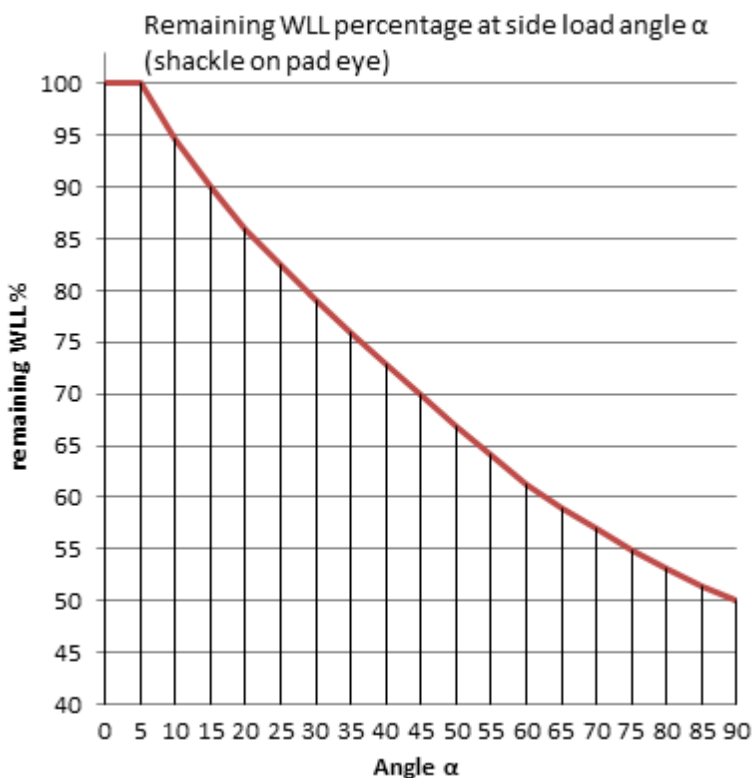
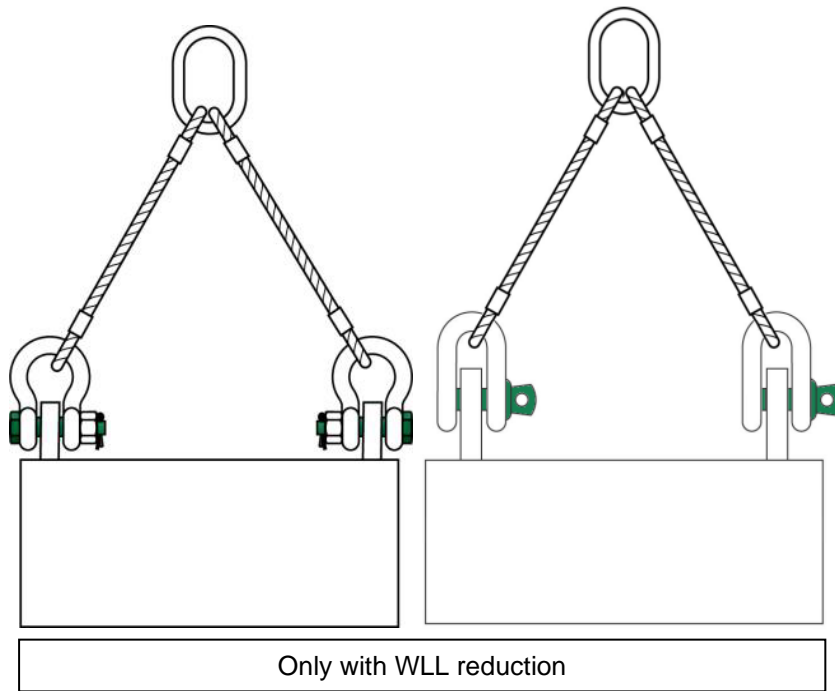

In-line loading is considered to be a load perpendicular to the pin and in the plane of the bow. Load angles in the table are the deviating angles from the in line loads.

To reduce bending stresses in the shackle, the shackle eyes diameter shall not exceed 110% of shackle bolts diameter. For greater shackle eye diameters, stable sleeves should be applied. Contact points to shackle bolt should be round / without edges.

When using shackles in connection with multi-leg slings, due consideration should be given to the effect of the angle between the legs of the sling. As the angle increases, so does the load in the sling leg and consequently in any shackle attached to that leg.

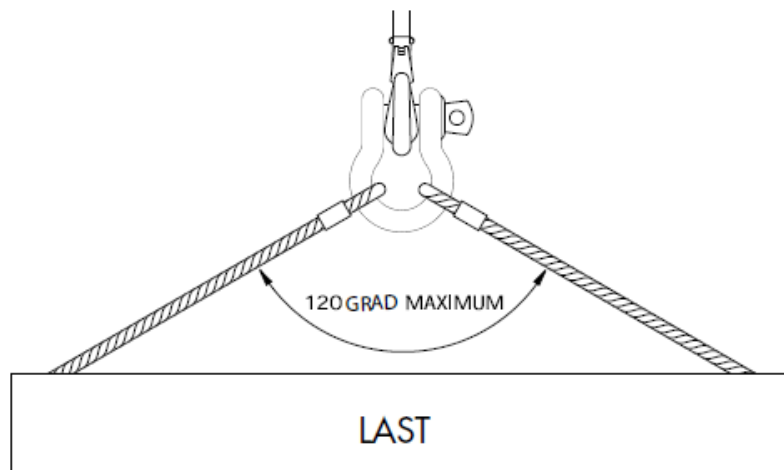

When a shackle is used to connect two slings to the hook of a lifting device, a bow type shackle must be assembled with the slings in the shackle body and the hook engaged with the shackle pin. The angle between the slings should not exceed 120°. If symmetrically loaded the shackle may be used to the full WLL.

To avoid eccentric loading of the shackle a loose spacer may be used on either end of the shackle pin. Do not reduce the width between the shackle jaws by welding washers or spacers to the inside faces of the eyes or by closing the jaws, as this will affect the properties of the shackle.

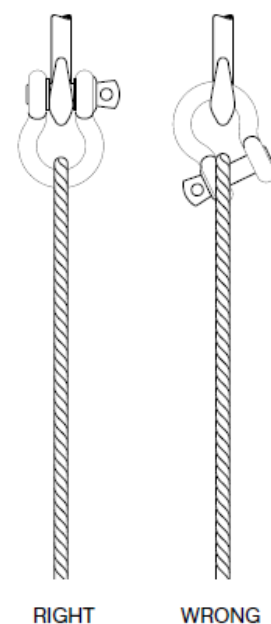

RIGHT

WRONG

When a shackle is used to secure the top block of a set of wire rope blocks the load on this shackle is increased by the value of the hoisting effect.

Avoid applications where due to movement (e.g. of the load or the rope) the shackle pin can rotate and possibly be unscrewed. If such an application is necessary or when the shackle is to be left in place for a prolonged period or where maximum pin security is required, use a shackle with a safety bolt, nut and pin cotter pin.

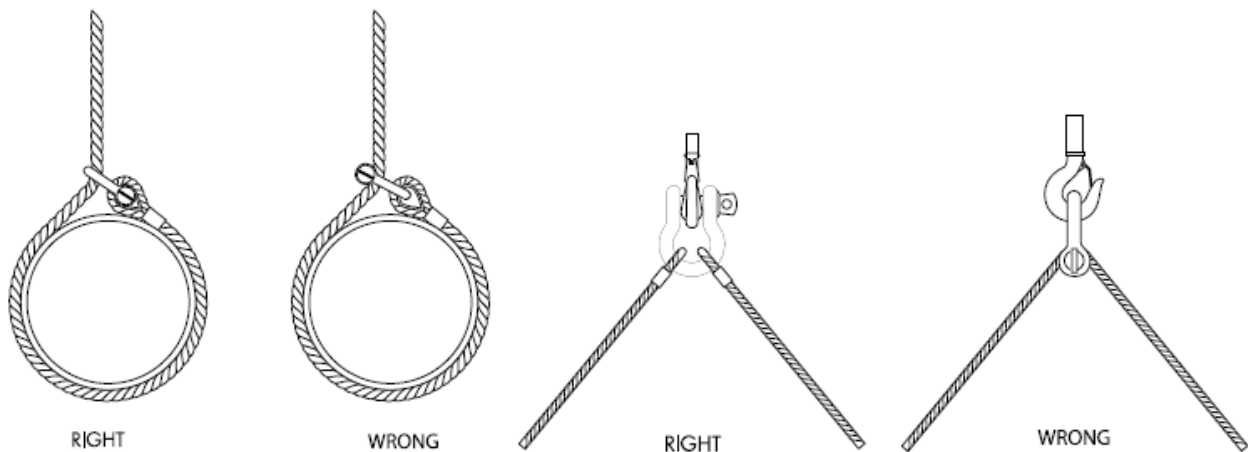

Shackles should not be immersed in acidic solutions or exposed to acid fumes or other chemicals that are potentially harmful for the shackle. Please be aware that these types of chemicals are used in certain production processes.

4. Point loading

Most of the time the load bearing component that is in connection with a shackle is of a rounded shape. Point loading of shackles is allowed but the minimum diameter of a rounded component should be equal or bigger than the bow size of the shackle being used. Bigger diameters and/or flat parts (at shackle pin side) to increase contact area can be beneficial.

Is the load width smaller than 60% of inner shackle width, centering discs on both sides must be used for loading shackle bolt in the middle. Is the load width smaller than 1 x diameter of shackle bow, than additional sleeves for reducing point load must be used.

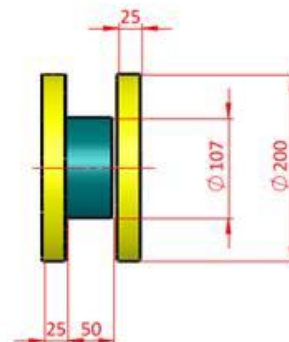
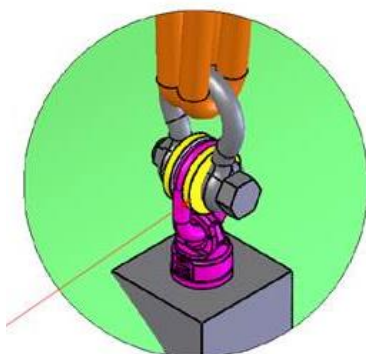

(Examples)

Sharp edges must be avoided.

Green Pin shackles can also be used in below configurations. The maximum load of the configuration is limited by the component with the lowest WLL.

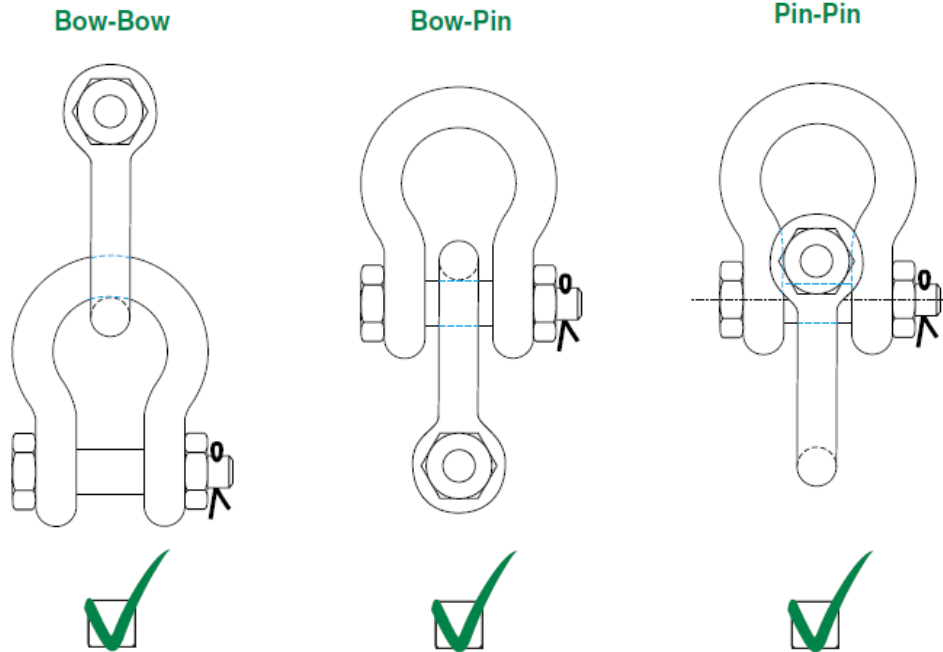

The crown of a Green Pin® Sling shackle is wider than that of a standard shackle, thus creating a bigger bearing surface. This improves the lifetime of the sling. Green Pin® Sling shackles can also be used in below configurations. The maximum load of the configuration is limited by the component with the lowest WLL.

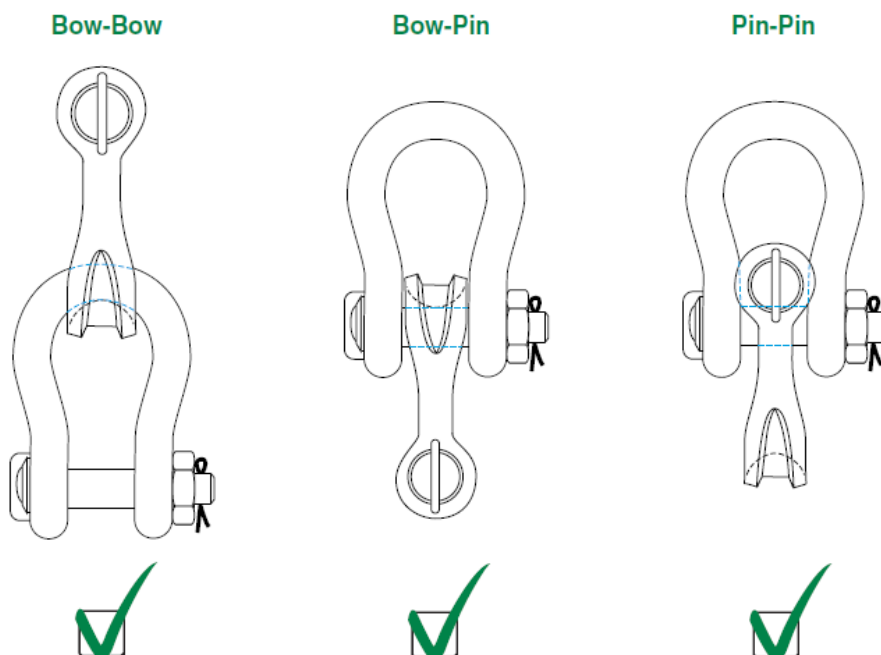

Pin- Pin configuration:

When the shackle eyes touch and the pins do not bear properly, the configuration should not be used.

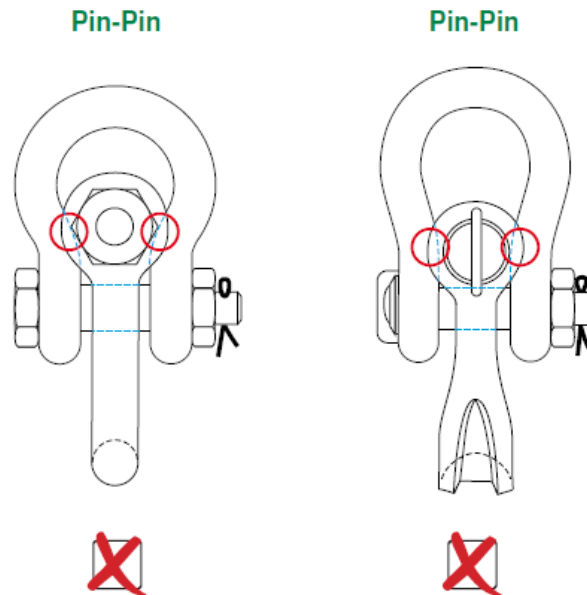

Bow- Pin configuration:

When the shackle body of the inner shackle touches the shackle eyes of the outer shackle and body and pin do not bear properly, the configuration should not be used.

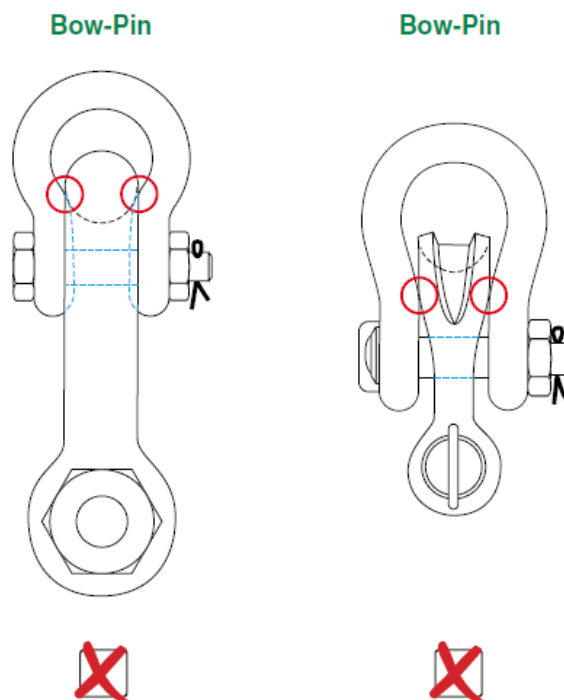

5. Temperature

If extreme temperature situations are applicable, the following load reduction must be taken into account:

Temperature	Reduction for elevated temperatures Temperature New Working Load Limit)
-40°C up to 200°C	100% of original Working Load Limit
200 – 300°C	90% of original Working Load Limit
300 – 400°C	75% of original Working Load Limit
> 400°C	Not allowed

Polar shackles can be used till -60°C.

The rating of shackles to EN 13889 assumes the absence of exceptionally hazardous conditions. Exceptionally hazardous conditions include offshore activities, the lifting of persons and the lifting of potentially dangerous loads such as molten metals, corrosive materials or fissile materials. In such cases a competent person should assess the degree of hazard and the safe working load should be reduced accordingly from the Working Load Limit.

6. Inspection

It is required that the shackles are regularly inspected and that the inspection should take place in accordance with the safety standards given in the country of use. This is required because the products in use may be affected by wear, misuse, overloading etc. with a consequence of deformation and alteration of the material structure. Inspection should take place at least every six months and even more frequently when the shackles are used in severe operating conditions.

Shackles should be inspected to ensure that:

- all markings are legible;
- the body and pin are both identifiable as being of the same size, type and make;
- the threads of the pin and the body are undamaged;
- for a safety bolt type shackle is used with the split cotter pin;
- the body and the pin are not distorted or unduly worn;
- the body and pin are free from nicks, gouges, cracks and corrosion;
- shackles are not heat treated as this may affect their Working Load Limit;
- the shackle is not modified, repaired or reshaped by welding, heating, machining or bending as this will affect the Working Load Limit;

Remove the shackle from service if:

- all markings are not clearly legible;
- body and pin can not be identified as being from same size, type and make;
- the threads of the pin and/or body are damaged;
- for a safety bolt type shackle the split cotter pin is missing;
- the body and/or pin is distorted or unduly worn, the maximum allowable wear is 10% of the original dimension;
- the body and/or pin is not free from nicks, gouges, cracks or corrosion;
- the shackle has been exposed to any heat treatment;
- the shackle is modified, repaired or reshaped by welding, heating, machining or bending;
- it is expected that before the next periodical inspection any of the inspection criteria above will not be passed;