

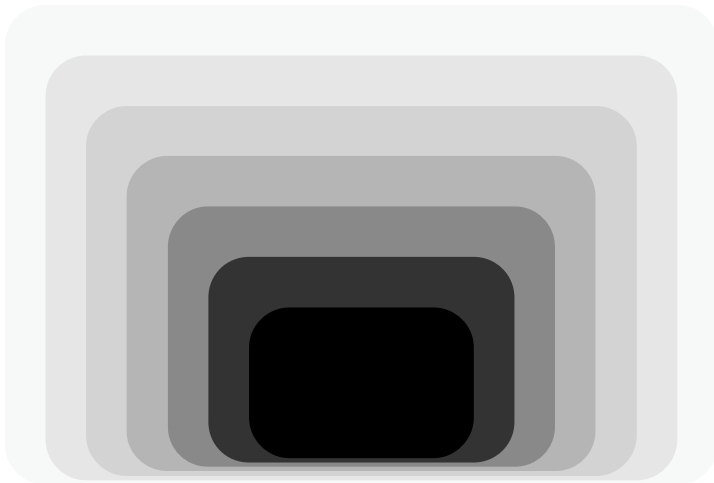

Strapping Machine JK-5000

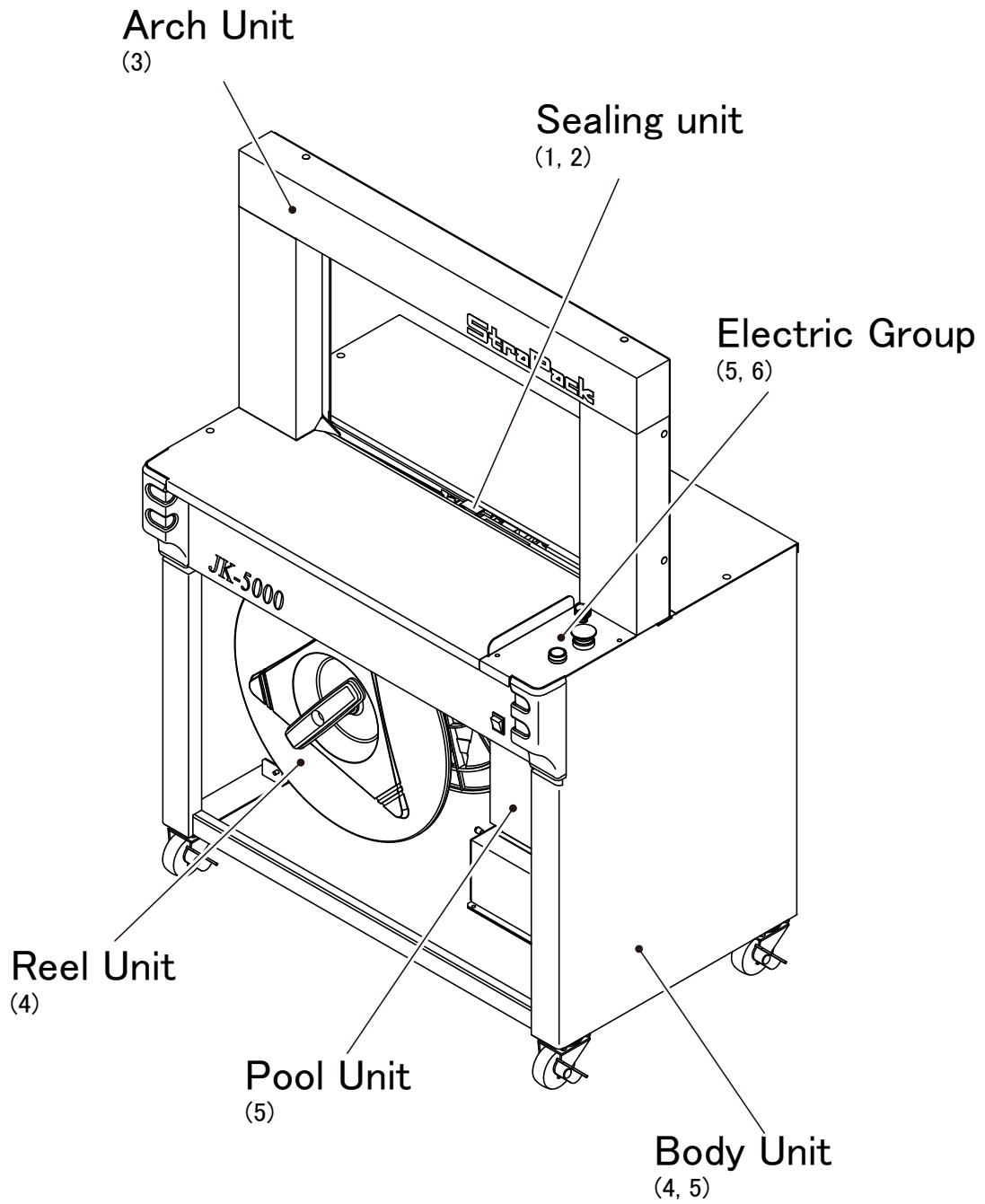

PARTS LIST



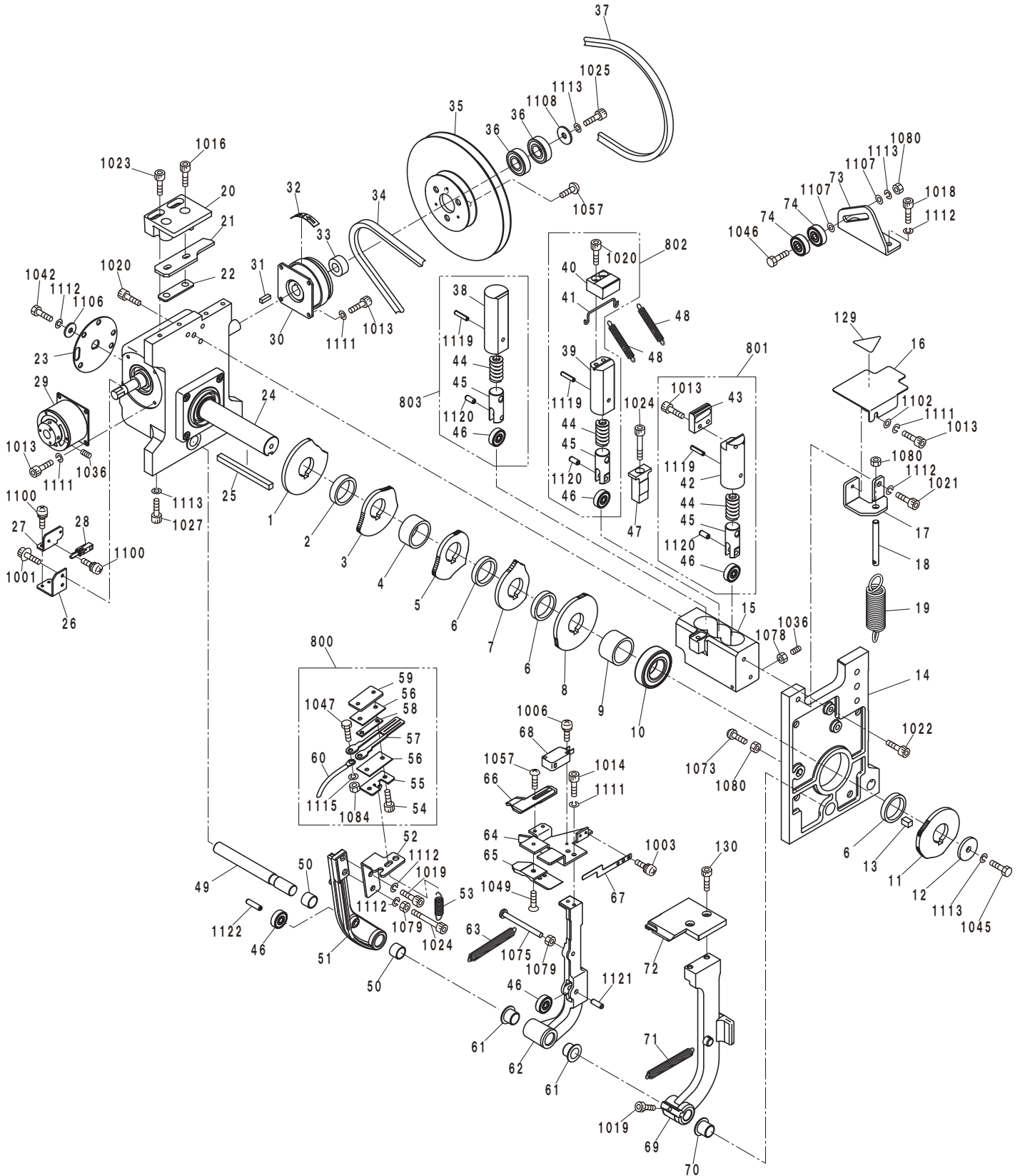

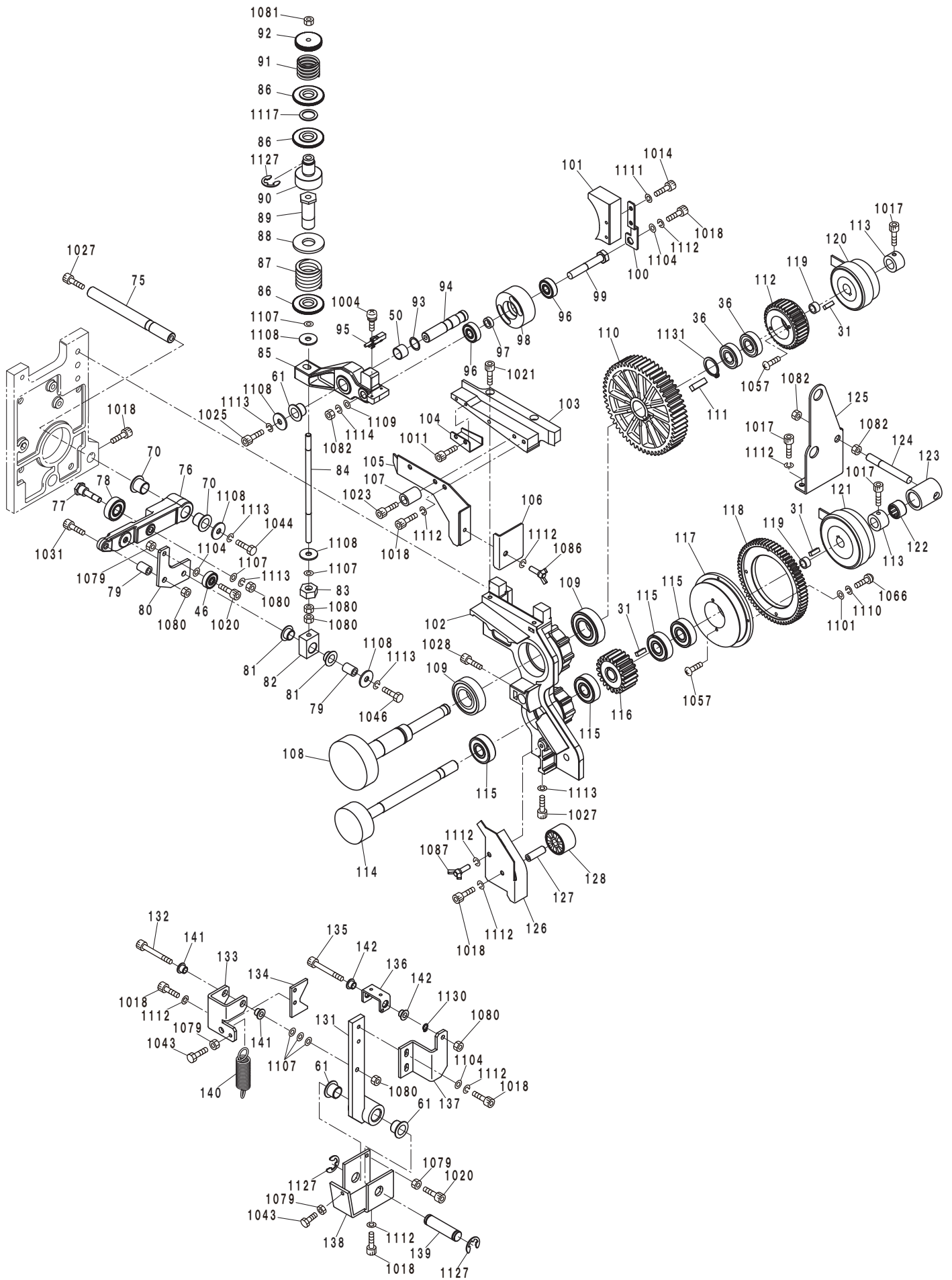

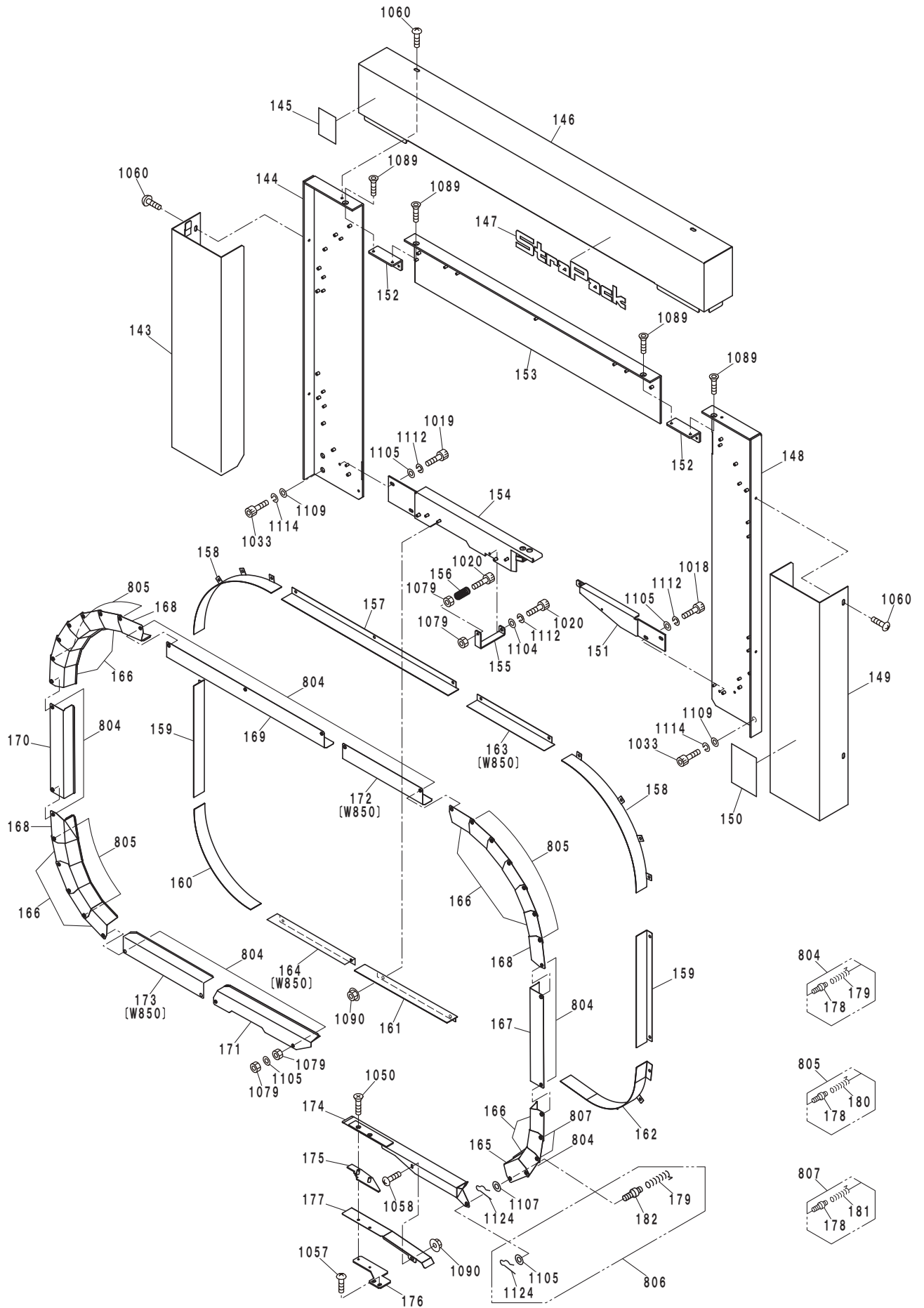

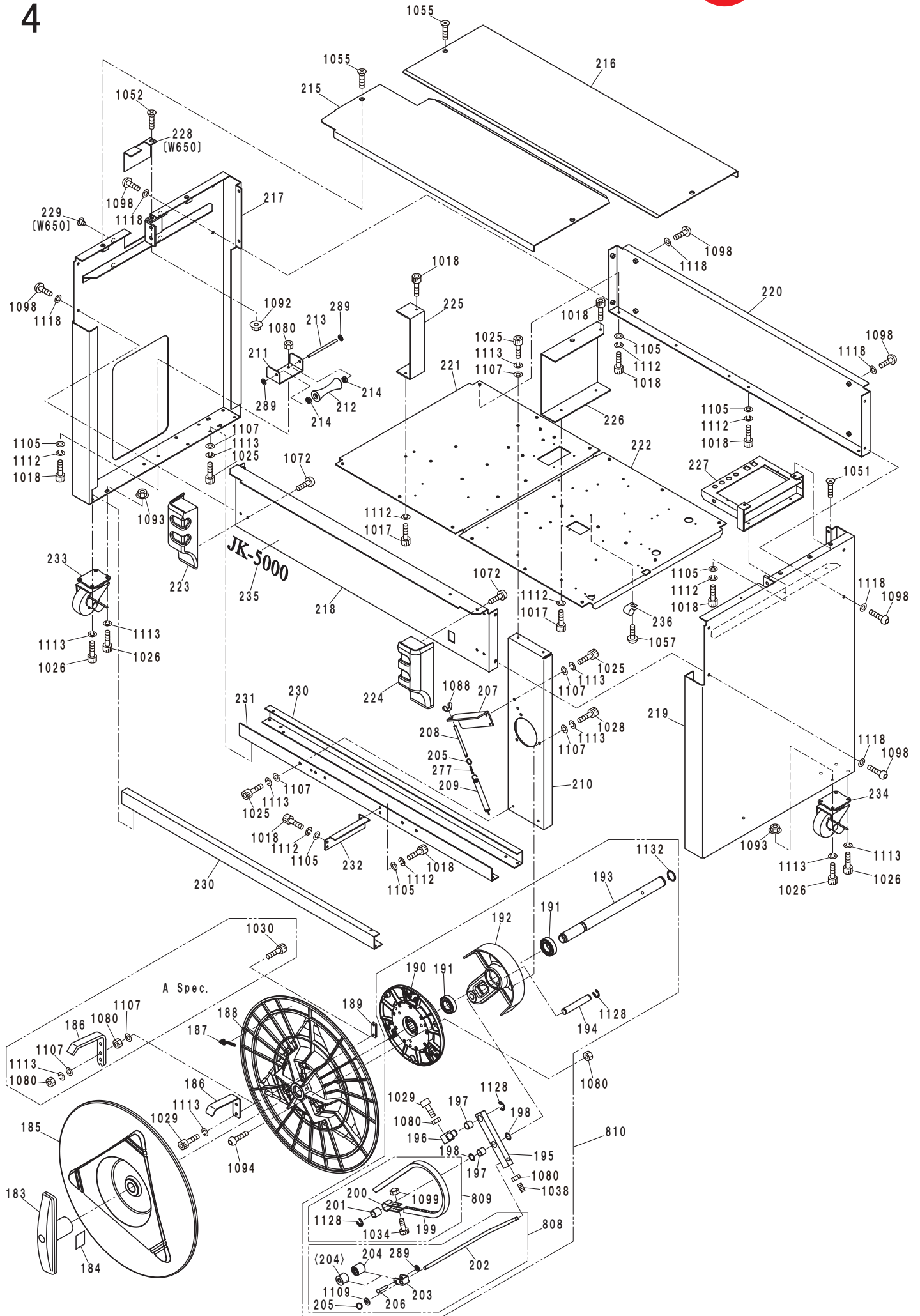

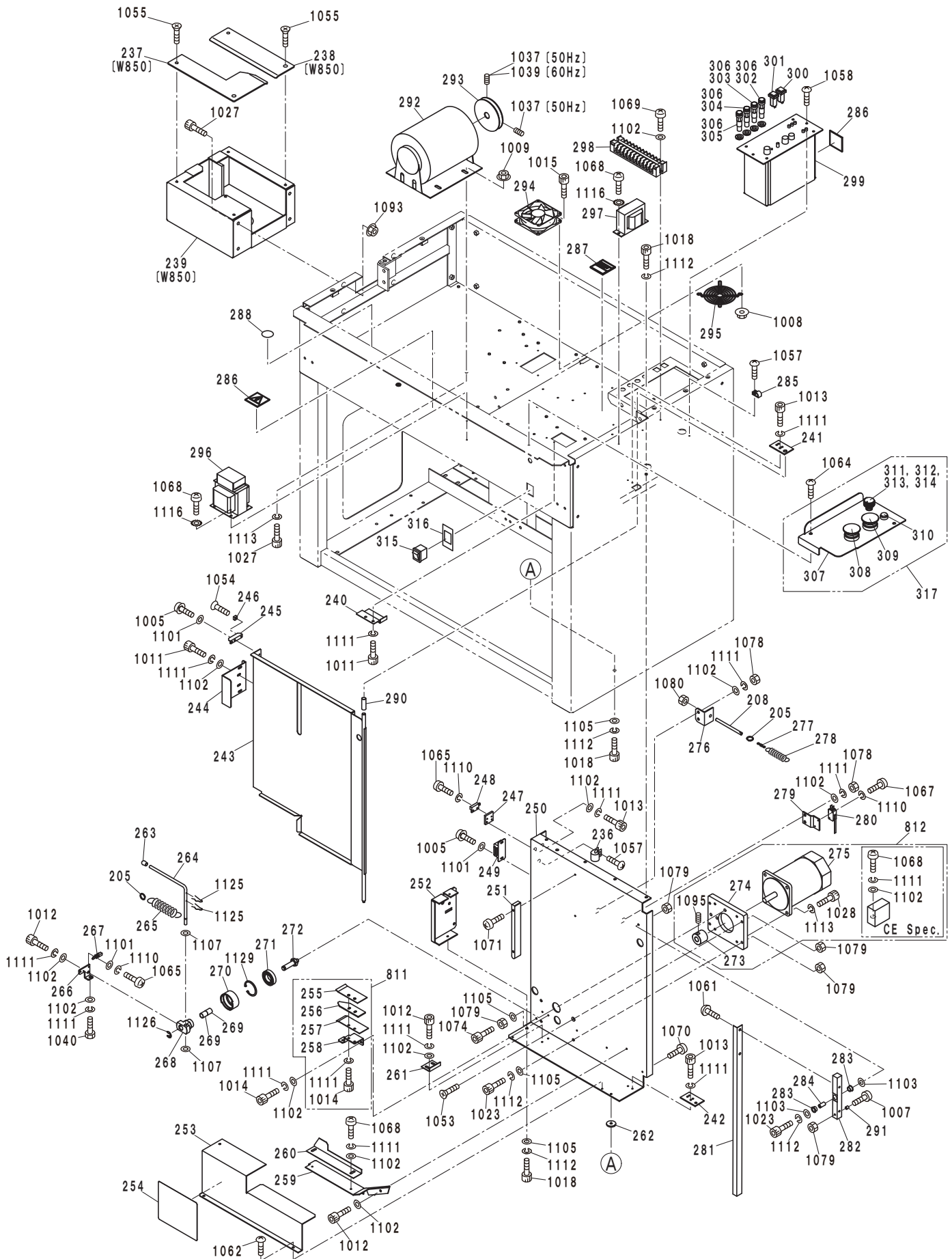

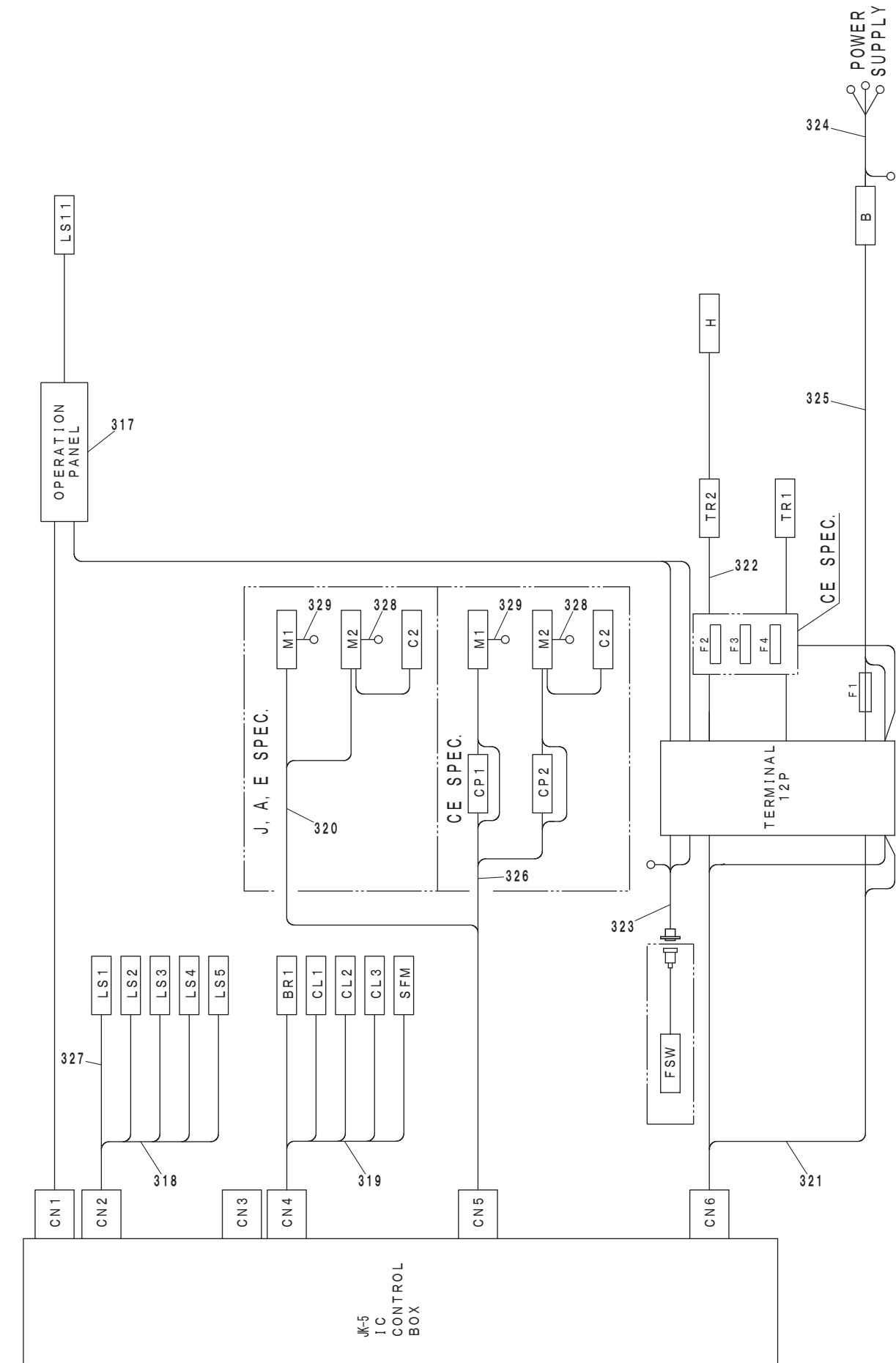





















略称 Abbreviation	名称 Designation	形状 Appearance	略称 Abbreviation	名称 Designation	形状 Appearance	略称 Abbreviation	名称 Designation	形状 Appearance
HBS	六角穴付きボルト Hexagon Socket Head Cap Bolt		CN	袋ナット Cap Nuts		H	C形止め輪(穴用) Retaining Rings C Type,Hole	
HSS	六角穴付き止めねじ Hexagon Socket Set Screws		WB	蝶ボルト Wing Bolt		S	C形止め輪(軸用) Retaining Rings C Type,Shaft	
HB	六角ボルト Hexagon Head Bolt		WN	蝶ナット Wing Nuts		HFS	六角穴付きサラ小ネジ Hexagon Socket Countersunk Head Screws	
FMS	十字穴付きサラ小ネジ Cross Recessed Flat Head Screws		SNPIN	スナップピン Snap Pin		SNB	角根丸頭ボルト Cup Head Square neck Bolt	
TMS	十字穴付きトラス小ネジ Cross Recessed Truss Head Screws		PW	平座金 Plain Washers		HBB	六角穴付きボタンボルト Hexagon Socket Button Head Screws	
PMS	十字穴付きナベ小ネジ Cross Recessed Pan Head Screws		SW	バネ座金 Spring Washers		HN-C	皿バネ付きナット Hex Nut with Disc Spring	
HN	六角ナット Hexagon Nuts		SPPIN	スプリングピン Spring Pin		HN-F	フランジ付きナット Hexagon Nuts with Flange	
HN-3	六角ナット(3種) Hexagon Nuts (Thin)		E	E形止め輪 Retaining Rings E Type				

番号 Ref. No.	部品番号 Parts. No.	部品名称 Description	番号 Ref. No.	部品番号 Parts. No.	部品名称 Description	番号 Ref. No.	部品番号 Parts. No.	部品名称 Description
1001	0016-103008	HBS-SP M3x8	1058	0151-104008	TMS M4x8	1115	0322-050913	SW M5 (5.1x9.2xt1.3) Stainless
1002	0016-104010	HBS-SP M4x10	1059	0151-104012	TMS M4x10	1116	0332-040804	TW M4 Stainless
1003	0037-103006	PMS-SP M3x6	1060	0151-105008	TMS M5x8	1117	0341-142003	Wave Washer φ14
1004	0036-103006	PMS-SP M3x8	1061	0151-105010	TMS M5x10	1118	0391-000005	PW M6
1005	0036-103008	PMS-S M3x6	1062	0151-604006	TMS M4x6	1119	0411-304018	Spring Pin φ4x18
1006	0037-103015	PMS-S M3x15	1063	0152-004006	TMS M4x6 Stainless	1120	0411-305012	Spring Pin φ5x12
1007	0037-105050	PMS-S M5x50	1064	0152-005008	TMS M5x8 Stainless	1121	0411-305015	Spring Pin φ5x15
1008	0041-104000	HN-F M4	1065	0161-103006	PMS M3x6	1122	0411-305020	Spring Pin φ5x20
1009	0041-106000	HN-F M6	1066	0161-103012	PMS M3x12	1123	0491-106001	HN-F M6
1010	0111-006015	HBS M6x15 Stainless	1067	0161-103018	PMS M3x18	1124	0491-120500	Snap Pin φ5
1011	0111-104006	HBS M4x6	1068	0161-104008	PMS M4x8	1125	0491-120600	Snap Pin φ6
1012	0111-104008	HBS M4x8	1069	0161-104010	PMS M4x10	1126	0511-110808	Stop Ring E-8
1013	0111-104010	HBS M4x10	1070	0161-104020	PMS M4x20	1127	0511-111010	Stop Ring E-10
1014	0111-104012	HBS M4x12	1071	0161-104025	PMS M4x25	1128	0511-111210	Stop Ring E-12
1015	0111-104015	HBS M4x15	1072	0161-105012	PMS M5x12	1129	0511-123716	Stop Ring H-37
1016	0111-104020	HBS M4x20	1073	0161-105020	PMS M5x20	1130	0511-130607	Stop Ring S-6
1017	0111-105008	HBS M5x8	1074	0161-105035	PMS M5x35	1131	0511-132012	Stop Ring S-20
1018	0111-105010	HBS M5x10	1075	0161-105055	PMS M5x55	1132	0511-132512	Stop Ring S-25
1019	0111-105012	HBS M5x12	1076	0162-004006	PMS M4x6 Stainless			
1020	0111-105015	HBS M5x15	1077	0181-103001	HN M3 style1			
1021	0111-105016	HBS M5x16	1078	0181-104001	HN M4 style1			
1022	0111-105020	HBS M5x20	1079	0181-105001	HN M5 style1			
1023	0111-105025	HBS M5x25	1080	0181-106001	HN M6 style1			
1024	0111-105040	HBS M5x40	1081	0181-106003	HN M6 style3			
1025	0111-106010	HBS M6x10	1082	0181-108001	HN M8 style1			
1026	0111-106012	HBS M6x12	1083	0182-003001	HN Stainless			
1027	0111-106015	HBS M6x15	1084	0182-005001	HN M5 Stainless			
1028	0111-106020	HBS M6x20	1085	0201-203009	CN M3			
1029	0111-106025	HBS M6x25	1086	0211-205010	WB M5x10			
1030	0111-106030	HBS M6x30	1087	0211-205015	WB M5x15			
1031	0111-106035	HBS M6x35	1088	0221-206002	WN M6 style2			
1032	0111-106050	HBS M6x50	1089	0251-105010	HFS M5x10			
1033	0111-108015	HBS M8x15	1090	0291-104101	HN-C M4			
1034	0112-004020	HBS M4x20 Stainless	1091	0291-105099	HBB M5x10			
1035	0112-006020	HBS M6x20 Stainless	1092	0291-105101	HN-C M5			
1036	0121-104008	HSS M4x15 cup point	1093	0291-106013	HN-F M6			
1037	0121-106010	HSS M6x10 cup point	1094	0291-106211	HBB M6x20			
1038	0121-106020	HSS M6x20 cup point	1095	0291-106215	HSS M6x6 Double Point			
1039	0121-108010	HSS M8x10 cup point	1096	0291-306240	HSS M6x8 Double Point			
1040	0131-104008	HB M4x8	1097	0291-308022	HSSB φ8x20			
1041	0131-104015	HB M4x15	1098	0291-606205	HBB M6x12			
1042	0131-105010	HB M5x10	1099	0292-004100	Nylon Nut M4 Stainless			
1043	0131-105030	HB M5x30	1100	0299-000090	PMS-SP M3x6(small PW)			
1044	0131-106010	HB M6x10	1101	0311-030805	PW M3 (3.4x8xt0.5)			
1045	0131-106015	HB M6x15	1102	0311-041008	PW M4 (4.5x10xt0.8)			
1046	0131-106030	HB M6x30	1103	0311-051010	PW M5 (5.5x10xt1)			
1047	0132-005010	HB M5x10 Stainless	1104	0311-051208	PW M5 (5.5x12xt0.8)			
1048	0141-103006	FMS M3x6	1105	0311-051210	PW M5 (t1.0)			
1049	0141-104006	FMS M4x6	1106	0311-051616	PW M5 (5.5x16xt1.6)			
1050	0141-104010	FMS M4x10	1107	0311-061310	PW M6 (6.6x13xt1)			
1051	0141-105010	FMS M5x10	1108	0311-062016	PW M6 (6.6x20xt1.6)			
1052	0141-105012	FMS M5x12	1109	0311-081816	PW M8 (9x18xt1.6)			
1053	0141-105025	FMS M5x25	1110	0321-030607	SW M3 (3.1x5.9xt0.7)			
1054	0142-003008	FMS M3x8 Stainless	1111	0321-040810	SW M4 (4.1x7.6xt1)			
1055	0142-006012	FMS M6x12 Stainless	1112	0321-050913	SW M5 (5.1x9.2xt1.3)			
1056	0151-103006	TMS M3x6	1113	0321-061215	SW M6 (6.1x12.2xt1.5)			
1057	0151-104006	TMS M4x6	1114	0321-081520	SW M8 (8.2x15.4xt2)			

No.	Parts.No.	Description	Q'ty	Remarks	No.	Parts.No.	Description	Q'ty	Remarks
1	690-01-10210	Heater Cam	1		64	693-01-20110	Band Guide A	1	
2	690-01-10270	Cam Collar 7.7	1		65	693-01-20120	Band Guide B	1	
3	690-01-10220	Left Cam	1		66	JK5-01-20123	Band Guide Upper Plate(9~15.5mm)	1	J9~15.5mm
4	690-01-10280	Cam Collar 15.5	1			JK5-01-20130	Band Guide Upper Plate(5~12mm)	1	J5.6mm Ex9~12mm.1/4. 3/8.1/2
5	690-01-10230	Center Press Cam	1		67	693-01-20130	Striker	1	
6	690-01-10290	Cam Collar 5.5	3		68	0750-110063	Micro Switch D2RV-E	1	
7	690-01-10240	Banc Guide Cam	1		69	690-01-21120	Slide Table Arm	1	
8	690-01-10250	Right Press Cam	1		70	0520-131212	Metal Bush LFF-1212	3	
9	690-01-10310	Cam Collar 19.8	1		71	690-01-20190	Slide Table Arm Spring	1	
10	0611-060001	Ball Bearing 60/22ZZ	1		72	690-01-20110	Slide Table	1	
11	690-01-10260	FR Cam	1		73	690-01-70510	Belt Tension Bracket	1	
12	615-01-10211	End Plate	1		74	0611-020636	Ball Bearing 636ZZ	2	
13	690-01-11170	Key, 6x6x9	1		75	690-01-50130	Frame Stay, Rear Lower	1	
14	690-01-50120	Right Flame	1		76	690-01-71120	FR Controll Arm	1	
15	690-01-30120	Guide Box	1		77	690-01-71130	Bearing Shaft	1	
16	690-01-40110	Heater Cover	1		78	0611-026000	Ball Bearing 600ZZ	1	
17	690-01-70260	Spring Adjust Bracket	1		79	690-01-70220	Controll Rod Collar	2	
18	690-01-70250	Spring Adjust Bolt	1		80	JK5-01-70312	Right Bandway Drive Plate	1	
19	900-01-80130	Right Bandway Spring	1		81	0520-131006	Metal Bush LFF-1006	2	
20	693-01-20210	Band Width Block	1		82	690-01-72220	Controll Rod Holder	1	
21	693-01-20220	Band Guide Plate	1		83	690-01-72230	Feed Nut	1	
22	693-01-20230	Band Guide Nut	1		84	690-01-72210	FR Controll Rod	1	
23	690-01-10360	Timing Plate	1		85	690-01-72120	Touch Roller Arm	1	
24	JK5-01-11200	Gear Box Assembly	1		86	690-01-72251	Spring Adjust Nut	3	
25	690-01-11160	Key, 6x6x77	1		87	690-01-72270	Tension Spring	1	
26	690-01-10370	Proximity Switch Bracket A	1		88	690-01-72260	Spring Collar	1	
27	690-01-10380	Proximity Switch Bracket B	1		89	690-01-72240	Spring Holder	1	
28	690-06-10170	Proximity Switch LS2	1		90	690-01-72280	Reverse Spring Bolt	1	
29	690-01-10500	Magnetic Brake Set (BR1)	1		91	JK5-01-70360	Reverse Spring	1	
30	690-01-10400	Magnetic Clutch Set (CL1)	1		92	690-01-72310	Control Rod Tpo Nut	1	
31	690-01-11180	Key 4x4x12	4		93	0770-140060	Sim Washer $\phi 12.3 \times \phi 15.7 \times 0.1t$	1	
32	690-01-10340	Seal(Home Position)	1		94	690-01-70230	Touch Roller Arm Shaft	1	
33	690-01-10330	Clutch Collar, CL1	1		95	690-06-10130	Proximity Switch, LS-3	1	
34	0810-151527	V Belt M-27	1		96	0611-020608	Ball Bearing 608ZZ	2	
35	690-01-10320	Gear Box Pulley	1		97	690-01-72140	Collar, Touch Roller	1	
36	0611-026001	Ball Bearing 6001ZZ	4		98	693-01-70120	Touch Roller	1	
37	0810-151525	V Belt M-25	1	60Hz	99	JK5-01-70421	Touch Roller Shaft	1	
	0810-151526	V Belt M-26	1	50Hz	100	JK5-01-70410	Guide Box Link Plate	1	
38	690-01-33110	Left Block	1		101	693-01-70130	Band Guide Block	1	
39	690-01-32110	Center Block	1		102	693-01-70110	FR Base	1	
40	690-01-32120	Cutter Lower	1		103	693-01-70140	FR Shooter	1	
41	690-01-32130	Spring Hook	1		104	693-01-70150	Lower Shooter	1	
42	690-01-31110	Right Block	1		105	693-01-70160	FR Shooter Cover	1	J9~15.5mm
43	690-01-31120	Cutter Upper	1			693-50-31110	FR Shooter Cover	1	J5.6mm Ex9~12mm.1/4. 3/8.1/2
44	660-01-31120	Right Block Spring	3		106	693-01-70170	Band Guide Block Stopper	1	
45	690-01-31130	Cam Follower Holder	3		107	JK5-01-70290	Right Bandway Rail	1	
46	0611-020635	Ball Bearing 635ZZ	6		108	JK5-01-70112	Reverse Roller	1	
47	690-01-20160	Slide Table Support	1		109	0611-026004	Ball Bearing 6004ZZ	2	
48	690-01-30130	Press Tension Spring	2		110	690-01-70142	Reverse Gear	1	
49	690-01-20170	Slide Table Frame Shaft	1		111	690-01-70150	Key 6x6x20	1	
50	0520-111210	Metal Bush K5B1210	3		112	JK5-01-70122	Reverse Gear(high speed)	1	
51	690-01-42120	Heater Arm	1		113	690-01-70210	FR Clutch End Collar	2	
52	690-01-42130	Heater Bracket	1		114	690-01-70160	Feed Roller	1	
53	690-01-40120	Heater Spring	1		115	0611-026201	Ball Bearing 6201ZZ	4	
54	690-01-41170	Heater Bolt	2		116	690-01-70170	Feed Gear	1	
55	690-01-41123	Heater Base	1		117	JK5-01-70172	FR Pulley	1	
56	690-01-41132	Insulating Board A	2		118	JK5-01-70191	Feed Gear(high speed)	1	
57	690-01-41114	Heater Nichrome Plate	1		119	690-01-70190	FR Clutch Collar	2	
58	690-01-41141	Insulating Board B	1		120	JK5-01-70342	Magnet Clutch, CL3	1	
59	690-01-41161	Heater Fixing Plate	1		121	JK5-01-70331	Magnet Clutch, CL2	1	
60	690-01-41152	Wire Harness(Heater)	2		122	0660-541216	One Way Clutch HF1216	1	
61	0520-131210	Metal Bush LFF-1210	5		123	690-01-70410	One Way Clutch Holder	1	
62	690-01-22120	Badn Guide Arm	1		124	JK5-01-70230	Holder Shaft	1	
63	690-01-20180	Band Guide Arm Spring	1		125	JK5-T1-70224	Fixing Plate	1	

No.	Parts.No.	Description	Q'ty	Remarks	No.	Parts.No.	Description	Q'ty	Remarks
126	JK5-01-70350	FR Band Guide	1		164	JK5-02-10260	Bandway Left Lower	1	W850,9~15.5mm
127	690-01-70310	Band Guide ROller Shaft	1			JK5-02-10270	Bandway Left Lower	1	W850,5~6,1/4, EX9~12mm
128	690-01-70320	Band Guide Roller	1		165	900-02-30170	Corner Flap (END) Fourth Corner	1	
129	0890-480257	Label(Warning)	1		166	900-02-30120	Corner Flap	19	
130	900-01-20211	Slide Tasble Screw, M5x18	2		167	900-20-12160	Side Flap, Right H400	1	H400
131	JK5-01-80113	Right bandway Arm	1			900-20-13160	Side Flap, Right H500	1	H500
132	JK5-01-80123	Holder, Open/Close Plate	1			900-20-14160	Side Flap, Right H600	1	H600
133	JK5-01-80153	Stopper Plate	1		168	900-02-30140	Corner Flap (END)	3	
134	JK5-01-80144	Plate, Arm Open/Close	1		169	900-02-30110	Flap, Upper	1	
135	900-01-81170	Joint Bolt	1		170	900-20-12170	Side Flap, Left H400	1	H400
136	900-01-81152	Right Bandway Joint	1			900-20-13170	Side Flap, Left H500	1	H500
137	JK5-01-80210	Right Bandway Bracket	1			900-20-14170	Side Flap, Left H600	1	H600
138	JK5-01-80173	Right Bandway Arm Base	1		171	JK5-02-10241	Flap Entrance	1	W850
139	JK5-01-80181	Right Bandway Shaft	1			JK5-02-10172	Flap, Entrance	1	W650
140	JK5-01-80191	Right Bandway Spring	1		172	900-20-13160	Side Flap, Right H500	1	W850
141	0520-130606	Metal Bush	2		173	JK5-02-10251	Flap Left Lower	1	W850
142	0520-140605	Flange Bush 80F-0605	2		174	JK5-02-10120	Right Bandway, Upper	1	
143	JK5-20-12140-000V	Arch Cover, Left H400	1	H400	175	JK5-02-10192	Band Adjuster	1	
	JK5-20-13140-000V	Arch Cover, Left H500	1	H500	176	JK5-02-10151	Right Bandway Base	1	
	JK5-20-14140-000V	Arch Cover, Left H600	1	H600	177	JK5-02-10140	Right Bandway, Lower	1	
144	JK5-20-12120-000V	Arch Frame, Left H400	1	H400	178	900-02-30221	Flap Stand	28	
	JK5-20-13120-000V	Arch Frame, Left H500	1	H500		900-02-30221	Flap Stand	30	W850
	JK5-20-14120-000V	Arch Frame, Left H600	1	H600	179	900-02-30310	Arch Flap Spring, ϕ 0.8	10	J 9~15.5mm
145	0890-480132	Label(Caution)	2	EX Spec.		906-02-30310	Arch Flap Spring, ϕ 0.8	10	1/4~5mm, EX9~12mm
	0890-480131	Label(Caution)	2	J Spec.		900-02-30310	Arch Flap Spring, ϕ 0.8	12	W850, J 9~15.5mm
146	JK5-61-10110-000V	Arch Cover, Upper W650	1	W650		906-02-30310	Arch Flap Spring, ϕ 0.8	12	W850,1/4~5mm, EX9~12mm
	JK5-62-10110-000V	Arch Cover, Upper W850	1	W850	180	900-02-30210	Arch Flap Spring, ϕ 0.65	17	J 9~15.5mm
147	900-02-10140	Label(Strapack)	1			906-02-30210	Arch Flap Spring, ϕ 0.65	17	1/4~5mm,EX9~12mm
148	JK5-20-12110-000V	Arch Frame, Right H400	1	H400	181	900-02-30210	Arch Flap Spring, ϕ 0.65	2	J 9~15.5mm
	JK5-20-13110-000V	Arch Frame, Right H500	1	H500		906-02-30210	Arch Flap Spring, ϕ 0.65	2	Ex9~12mm
	JK5-20-14110-000V	Arch Frame, Right H600	1	H600		906-02-30310	Arch Flap Spring, ϕ 0.8	2	1/4~5mm
149	JK5-20-12130-000V	Arch Cover, Right H400	1	H400		182	900-02-30423	Flap Joint Bolt	1
	JK5-20-13130-000V	Arch Cover, Right H500	1	H500	183	631-04-10170	Reel Nut Handle, Left	1	
	JK5-20-14130-000V	Arch Cover, Right H600	1	H600	184	0890-480293	Arrow Label (Nut Handle/left-hand/double thread)	1	
150	0890-480090	Label(Warning)	1	J Spec.	185	125-04-10122	Reel Out Circular	1	
151	JK5-02-10110	Band Guide Right	1		186	900-04-10150	Reel Center Guide	3	J,E,CE Spec.
152	900-02-10110	Connecting Plate	2			900-24-29110	Reel Center Guide	3	A Spec.
153	JK5-61-10120-000V	Arch Frame, Upper W650	1	W650	187	0890-480027	Arrow Label(Right Direction)	1	
	JK5-62-10120-000V	Arch Frame, Upper W850	1	W850	188	125-04-10112	Reel In Circular	1	
154	693-02-10110	Band Guide, Left	1	W650	189	125-04-10210	Rear Nut	3	
	693-62-12110	Band Guide Left 850W	1	W850	190	900-04-20400	Reel Brake Pulley Set	1	
155	JK5-02-10182	Flap Support	1		191	0611-026005	Ball Bearing 6005ZZ	2	
156	JK5-02-10210	Flap Spring	1	5~6,1/4,J9mm, EX9~15,5mm	192	900-04-20311	Reel Unit Base	1	
157	906-02-20120	Bandway, Upper	1	5~6,1/4, EX9~12mm	193	904-24-15100	Reel Shaft Set Left 360L	1	
	900-02-20120	Bandway, Upper	1	J9~15.5mm,EX15.5mm	194	900-04-20150	Holder Shaft	1	
158	906-02-20130	Bandway Corner, Upper	2	5~6,1/4,EX9~12mm	195	900-04-20142	Brake Tension Holder	1	
	900-02-20130	Bandway Corner, Upper	2	J9~15.5mm,EX15.5mm	196	900-04-20161	Brake Belt Tighten	1	
159	900-20-12150	Bandway, Side H400	2	H400,9~15.5mm	197	0520-111515	Metal Bush LFB-1515	2	
	906-20-12110	Bandway, Side 400H	2	H400,5~6,1/4,EX9~12mm	198	0770-140040	Shim ϕ 15idx ϕ 20.5odxt0.1	2	
	900-20-13150	Bandway, Side 500H	2	H500,9~15.5mm	199	900-04-22111	Brake Belt	1	
	906-20-13110	Bandway, Side 500H	2	H500,5~6,1/4,EX9~12mm	200	900-04-22120	Brake Belt Holder	1	
	900-20-14150	Bandway, Side 600H	2	H600,9~15.5mm	201	900-04-22130	Brake Belt Holder Collar	1	
906-20-14110	Bandway, Side 600H	2	H600,5~6,1/4,EX9~12mm	202	693-04-21110	Reel Brake Arm	1		
160	906-02-20110	Bandway Corner, Left Lower	1	5~6,1/4,EX9~12mm	203	100-04-22110	Bracket(Free Angle Roller)	1	
	900-02-20110	Bandway Corner, Left Lower	1	J9~15.5mm,EX15.5mm	204	100-04-11131	Band Guide Roller	1	J 8~15.5mm
161	JK5-02-10230	Bandway, Entrance	1	W650,5~6,1/4,EX9~12mm		249-04-11120	Free Angle Roller	1	1/4~5mm,EX9~12mm
	JK5-02-10220	Bandway, Entrance	1	W650,9~15.5mm	205	100-04-20190	Brake Tension Spring Ring	4	
	906-62-10110	Bandway Entrance 650W	1	W850,5~6,1/4,EX9~12mm	206	0421-106030	Rivet ϕ 6x30	1	
	900-62-10140	Bandway Entrance	1	W850,9~15.5mm	207	693-04-21210	Bracket(Feed Spring Adjuster)	1	
162	906-02-20141	Bandway Corner, Right Lower	1	5~6,1/4,EX9~12mm	208	300-01-72140	Feed Upper Roller Spring Adjuster	2	
	900-02-20141	Bandway Corner, Right Lower	1	J9~15.5mm,EX15.5mm	209	900-04-20171	Brake Tension Arm Spring	1	
163	900-62-10160	Bandway Extension 200L	1	W850,9~15.5mm	210	693-04-20110-000V	Reel Unit Base	1	
	906-62-10130	Bandway Extension 200L 6mm	1	W850,5~6,1/4, EX9~12mm	211	693-04-11110	Bracket(Guide Roller)	1	
					212	693-04-11120	Guide Roller	1	

No.	Parts.No.	Description	Q'ty	Remarks	No.	Parts.No.	Description	Q'ty	Remarks
213	693-04-11130	Guide Roller Shaft	1		275	0780-140086	Motor	1	J Spec.
214	0611-020696	Ball Bearing 696ZZ	2			0780-140096	Motor	1	A Spec.
215	JK5-05-12190	Upper Table, Front	1	W650		0780-140097	Motor	1	E,CE Spec.
	JK5-62-12120	Upper Table Front	1	W850	276	914-03-30110	Bracket(Adjuster)	1	
216	JK5-05-11261	Upper Table, Rear	1		277	0890-290001	Twist Stopper	2	
217	693-05-12130-300	Body Side Left	1		278	900-03-20360	Pusher Return Spring	1	
218	693-05-12110-000V	Body Front	1		279	904-03-30311	Pool Switch Base	1	
219	693-05-12140-300	Body Side Right	1		280	0750-110090	Micro Switch VX-013-1A3	1	
220	JK5-05-12120-000V	Body Rear	1		281	693-03-10310	Balance Bar	1	
221	693-05-12150	Body Bottom Left	1		282	914-03-30221	Balance Bar Holder	1	
222	693-05-12160	Body Bottom Right	1		283	0611-060029	Ball Bearing MF128ZZ1MC3	2	
223	JK5-05-12180	Protector Left	1		284	900-03-30232	Balance Bar Shaft	1	
224	JK5-05-12170	Protector Right	1		285	0740-160009	Nylon Clip NK-5N	1	
225	JK5-05-11211	Table Support Left	1		286	0890-480064	Safety Marking	3	EX Spec.
226	JK5-05-12250	Table Support Right	1			0890-480084	Safety Marking	3	J Spec.
227	693-05-12170	Bracket(Control Box)	1		287	0890-480127	Safety Marking	1	EX Spec.
228	JK5-05-12260-300	Body Side Cover	1	W650		0890-480116	Safety Marking	1	J Spec.
229	0890-340004	Clip 2488	4	W650	288	601-05-10180	Ground Seal	2	J Spec.
230	JK5-05-12220-300	Body Support	2			601-05-10180	Ground Seal	3	EX Spec.
231	693-05-12180-300	Body Support Center	1		289	0512-210600	Pushing Nut ϕ 6(Stainless)	3	
232	693-03-10120-300	Pool Box Support	1		290	0890-320256	Spacer 8x30	1	
233	690-05-10240	Swivel Caster(with Stopper)	4	EX Spec.	291	0890-320257	Spacer 5x6	1	
	0890-130309	Caster	2	J Spec.	292	690-83-10410	Motor	1	A Spec.
234	0890-130308	Caster	2	J Spec.		690-06-10410	Motor	1	J Spec.
235	693-05-12210	Label(JK-5000)	1			690-86-10410	Motor	1	E,CE Spec.
236	0740-160051	Nylon Clip NK-10N	4		293	JK5-06-10110	Motor Pulley	1	60Hz
237	JK5-05-11350	Upper Table Front 850W	1	W850		100-26-16140	Motor Pulley	1	50Hz
238	JK5-05-11360	Upper Table Rear 850W	1	W850	294	900-06-10160	Smoke Fan	1	
239	JK5-05-11291-300	Extra Size Box	1	W850	295	0780-170047	Smoke Fan Cover	1	
240	693-03-10140	Pool Band Stopper	1		296	693-83-10210	Heater Transformer	1	A Spec.
241	914-03-30241	Pool Door Hinge Upper	1			693-86-10210	Heater Transformer	1	CE Spec.
242	693-03-10220	Pool Door Hinge(Lower)	1			693-81-10210	Heater Transformer	1	E Spec.
243	693-03-10210-000V	Pool Box Door	1			693-06-10210	Heater Transformer	1	J Spec.
244	914-03-30132	Door Handle	1		297	693-83-10300	Control Transformer Set	1	A Spec.
245	693-03-61120	Magnet Bracket	1			693-86-10300	Control Transformer Set	1	CE Spec.
246	0750-130004	Magnet for Lead Switch	1			693-81-10300	Control Transformer Set	1	E Spec.
247	693-03-61110	Lead Switch Bracket	1			693-06-10300	Control Transformer Set	1	J Spec.
248	693-06-13120	Proximity Switch	1		298	10009395-6-5110	Terminal Base	1	
249	0890-160002	Magnet Catch	1		299	693-06-11000	IC Control Box Assembly	1	
250	693-03-10110-000V	Pool Box	1		300	0730-110139	Circuit Protector	1	CE Spec.
251	693-03-10130	Pool Band Guide A	1		302	0730-110140	Circuit Protector	1	CE Spec.
252	693-03-20120-000V	Touch Lever Guide	1			0730-170100	Fuse 10A ϕ 6.4x30(250V)	1	E,CE Spec.
253	693-03-10230-300	Pool Cover	1		0730-170150	Fuse 15A ϕ 6.4x30(250V)	1	J,A Spec.	
254	693-03-10240	Label(Threading Strap)	1		303	0730-170003	Fuse 0.3A ϕ 6.4x30(250V)	1	CE Spec.
255	900-03-12220	Pool Shooter In Lower	1		304	0730-170005	Fuse 0.5A ϕ 6.4x30(250V)	1	CE Spec.
256	900-03-12230	Pool Shooter Guide In	1		305	0730-170010	Fuse 1A ϕ 6.4x30(250V)	1	CE Spec.
257	900-03-12210	Pool Shooter In Upper	1		306	0730-130030	Fuse Holder	1	J,A,E Spec.
258	900-03-12240	Pool Shooter Bracket A	1			0730-130030	Fuse Holder	4	CE Spec.
259	693-03-20140	Band Keeper A	1		307	693-06-12110	Operation Panel	1	
260	693-03-20150	Band Keeper B	1		308	0710-110242	Start Switch	1	EX Spec.
261	693-03-20130	Touch Lever Stopper	1			0710-110243	Start Switch	1	J Spec.
262	631-01-70480	End Plate(B)	1		309	0710-110244	Stop Switch	1	
263	0890-180015	Rubber Knob	1		310	0710-140042	Push Button Switch	1	
264	693-03-20110	Touch Lever	1		311	0770-220011	Tension Volume 1k Ω	1	RV24YN-20SB
265	900-01-70140	Reverse Roller Release Spring	1		312	0710-180031	Tension Dial	1	NCR-28029-1
266	900-23-18130	Bracket(Proximity Switch)	1		313	100-01-62120	Rubber Packing	1	
267	693-06-13110	Proximity Switch	1		314	0291-109157	Pipe Nut	1	M9 ϕ 12x2
268	900-23-18120	Eccentric Shaft	1		315	0710-130036	Power Switch, LLLK35C1	1	
269	0520-111015	Metal Bush LFB-1015	2		316	631-80-10590	Seal(Power Supply Switch)	1	
270	900-23-18110	Lower Roller	1		317	693-80-12100	Operation Panel Set	1	EX Spec.
271	0611-026904	Ball Bearing 6904ZZ	1			693-06-12100	Operation Panel Set	1	J Spec.
272	900-03-11130	Lower Roller Shaft	1		318	693-06-30110	Wire Harness(Limit Switch)	1	
273	900-03-11320	Drive Roller	1		319	693-06-30120	Wire Harness(Brake, Clutch)	1	
274	900-03-11310	Pool Motor Base	1		320	693-06-30160	Wire Harness(Motor)	1	J,A,E Spec.

No.	Parts.No.	Description	Q'ty	Remarks	No.	Parts.No.	Description	Q'ty	Remarks
321	693-06-30130	Wire Harness(Transformer)	1		Assembly				
322	693-06-30170	Wire Harness(Heater Transformer)	1	J,A,E Spec.	800	690-01-41002	Heater Set	1	
	693-86-30170	Wire Harness(Heater Transformer)	1	CE Spec.	801	690-01-31000P	Right Block Assembly	1	
323	693-80-30210	Wire Harness(Foot Switch)	1	EX Spec.	802	690-01-32000P	Center Block Assembly	1	
324	690-06-30150	Power Supply Code	1	J Spec.	803	690-01-33000P	Left Block Assembly	1	
	690-82-10110	Power Supply Code	1	EX Spec.	804	900-02-30300P	Arch Flap Spring Set, ϕ 0.8	9	J 9~15.5mm
325	693-06-30140	Wire Harness(Power Supply Switch)	1			906-02-30300P	Arch Flap Spring Set, ϕ 0.8	9	1/4~5mm,Ex9~12mm
326	693-86-30160	Wire Harness(Motor)	1	CE Spec.		900-02-30300P	Arch Flap Spring Set, ϕ 0.8	12	W850,J 9~15.5mm
327	JK5-06-10291	Wire Harness(LS1)	1			906-02-30300P	Arch Flap Spring Set, ϕ 0.8	12	W850,1/4~5mm,Ex9~12mm
328	693-06-30150	Wire Harness(M2 Ground)	1		805	900-02-30200P	Arch Flap Spring Set, ϕ 0.65	17	J 9~15.5mm
329	690-06-30160	Wire Harness(Earth for Motor)	1			906-02-30200P	Arch Flap Spring Set, ϕ 0.65	17	1/4~5mm,Ex9~12mm
					806	900-02-30403P	Right Bandway Stand Set	1	J 9~15.5mm
						906-02-30403P	Right Bandway Stand Set	1	1/4~5mm,Ex9~12mm
					807	900-02-30200P	Arch Flap Spring Set, ϕ 0.65	2	J 9~15.5mm
						906-02-30200P	Arch Flap Spring Set, ϕ 0.65	2	Ex9~12mm
						906-02-30300P	Arch Flap Spring Set, ϕ 0.8	2	1/4~5mm
					808	-	Reel Brake Arm Assembly	1	J 9~15.5mm
						-	Reel Brake Arm Assembly	1	1/4~5mm,Ex9~12mm
					809	900-04-22000P	Brake Belt Assembly	1	
					810	-	Reel Unit Assembly	1	
						-	Reel Unit Assembly	1	
					811	-	Pool Shooter(In Set)	1	
					812	-	Pool Motor Assembly	1	
						-	Pool Motor Assembly	1	
						-	Pool Motor Assembly	1	